

Type2-Type2 32A/480V AC 7.5m

Ver	ECN	MARK	DESCRIPTION	DATE	APP	CHK

Type II
2-IIe

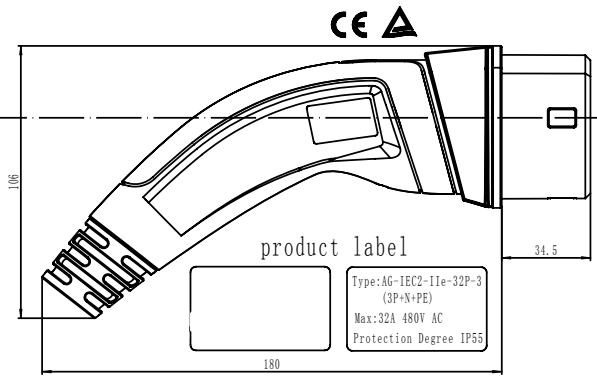
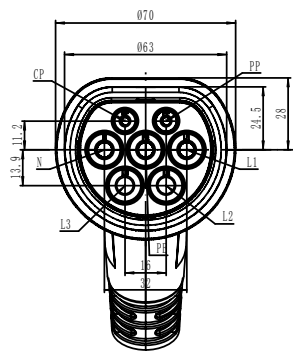

Technical parameters
 Current and Voltage : 32A 480V AC
 Signal current : 2A 30V
 Protection Degree : IP55 (Working status)
 Ambient temperature: -30° C to +50° C

Cable specification

Function	32A 480V AC	Function
L1 (1)	6 mm ² Brown	L1 (1)
L2 (2)	6 mm ² Black	L2 (2)
L3 (3)	6 mm ² Grey	L3 (3)
N (4)	6 mm ² Blue	N (4)
PE (5)	6 mm ² Yellow-green	PE (5)
CP (6)	0.5 mm ² White	CP (6)
PP (7)		PP (7)

Type II
2-IIb

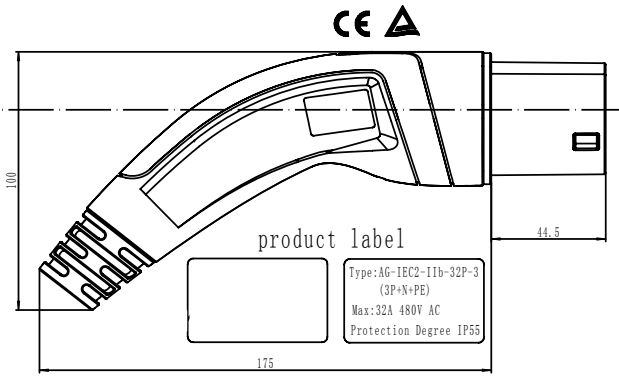
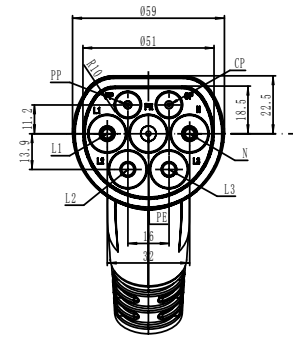

32A 3P+N+PE+PP+CP
 Type II , was designed according to the standard of IEC 62196-2 sheet 2-IIb/2-IIe
 The static resistance is 220 ohm
 Charging cable 7500mm 5*6mm²+2*0.5mm² Black TUV overall cable

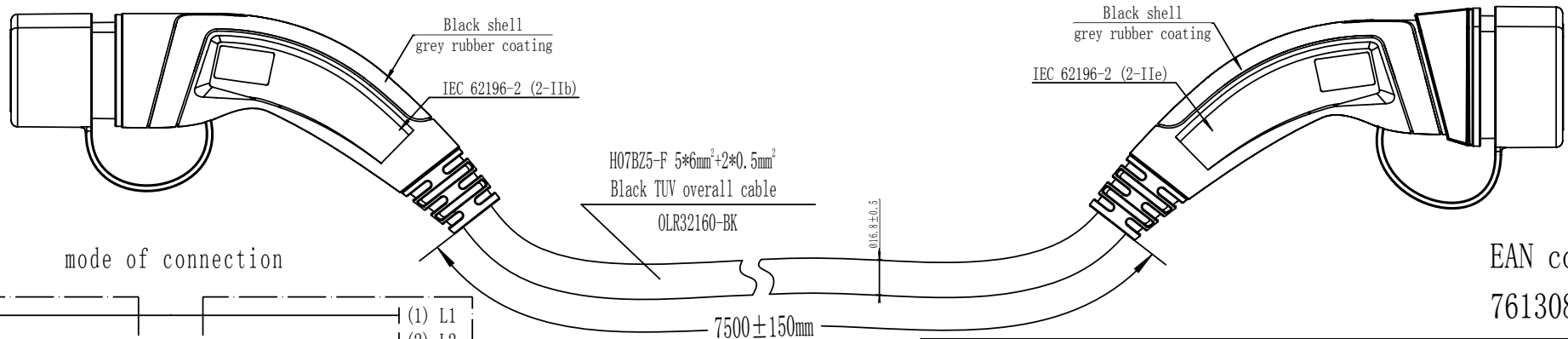

mode of connection

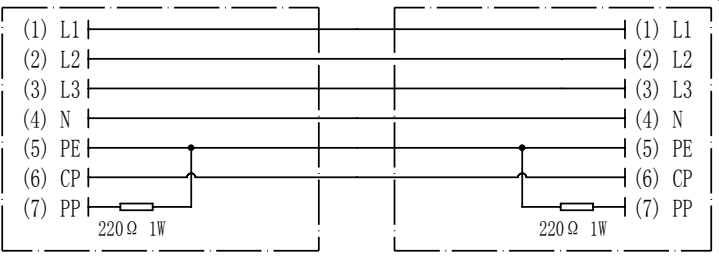

EAN code:
7613081070676

DWG. SYM	S A	PROJ. SYM				
MATL	Specifications		WEIGHT	NAME Charging connectors		
DESIGNED	CHECK	STDCHECKED	DRAW NO	SIZE A4	SCALE X:X	
CHECKED	PROCESS	APPROVED	PART NO	SHEET X OF X		